



**AVERY
DENNISON**

Fastener
Solutions

21" Heavy Duty Cable Ties Marketing Specifications

For the following part numbers:

10606-0

10607-0

10608-0

August 1, 2018

AVERY DENNISON MARKETING SPECIFICATION

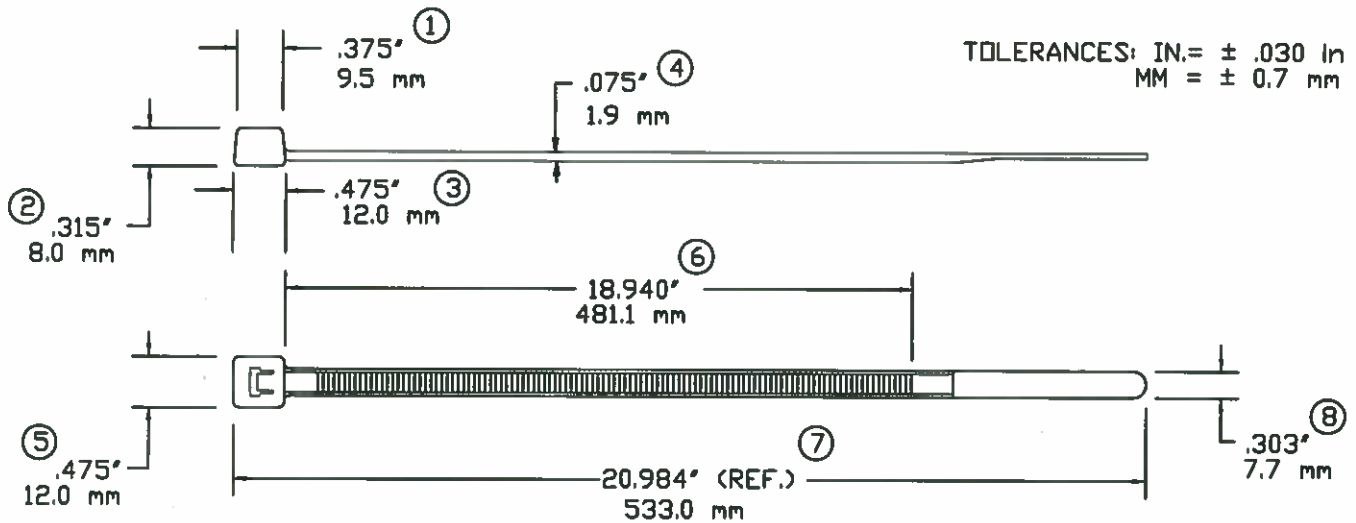

NOT TO SCALE

LOOP TENSILE STRENGTH:	120 LBF / 534N MINIMUM PER AS-23190
OPERATING TEMPERATURE:	-40°F(-40°C) TO 185°F(85°C)
MIN. INSTALLATION TEMP:	32°F(0°C)
MATERIAL:	NYLON 6/6
WEIGHT:	.2924 OZ./8.3 GRAMS
MILITARY STANDARD:	MS-3367-3-9
BUNDLE DIAMETER:	Ø.250"/4.76mm TO Ø6.0"/152.4mm
TOOL TENSION SETTING:	6-8 ON HEAVY DUTY TOOL
PACKAGED IN:	50/BAG, 1,000/CASE

NOTE: THESE CABLE TIES ARE PLENUM RATED AND HAVE A FLAMMABILITY RATING OF V-2.



FASTENER DIVISION
FITCHBURG, MA 01420 U.S.A.
TEL. 1-800-225-5913
FAX. 1-800-848-2169

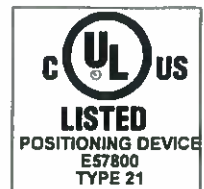

DESCRIPTION:

21" / 533mm CABLE TIE, HEAVY DUTY
NATURAL

APPROVAL:

L Boyle 9-15-2015

STOCK NO.

10606-0

REV

H

AVERY DENNISON MARKETING SPECIFICATION

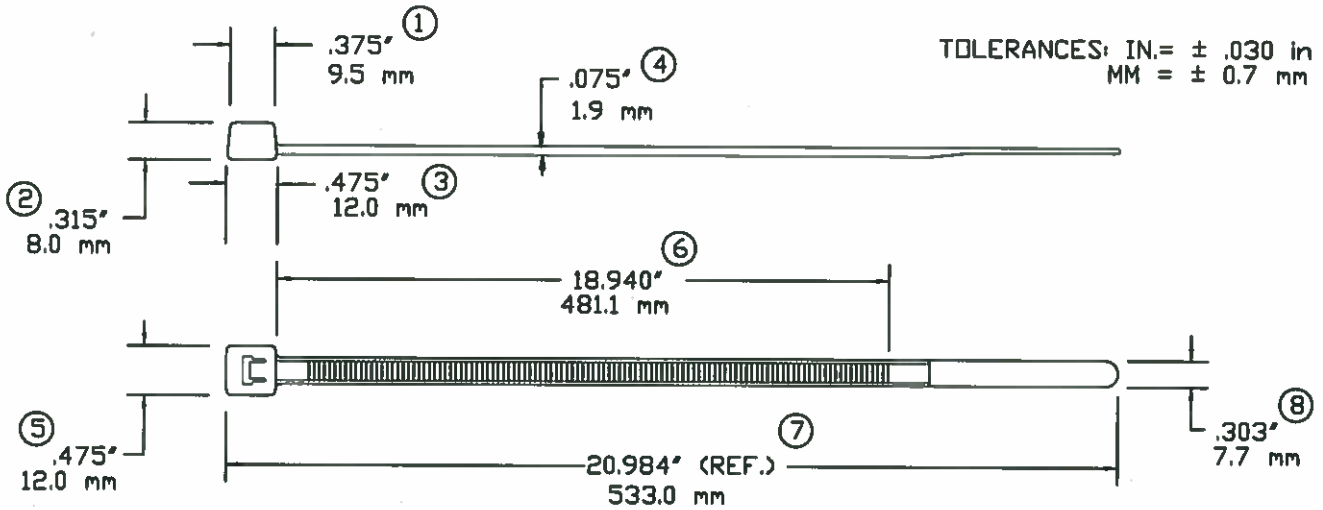

NOT TO SCALE

LOOP TENSILE STRENGTH:	120 LBF / 534N MINIMUM PER AS-23190
OPERATING TEMPERATURE:	-40°F(-40°C) TO 221°F(105°C)
MIN. INSTALLATION TEMP:	32°F(0°C)
MATERIAL:	NYLON 6/6
WEIGHT:	.2924 OZ./8.3 GRAMS
BUNDLE DIAMETER:	∅.250"/4.76mm TO ∅6.0"/152.4mm
TOOL TENSION SETTING:	6-8 ON HEAVY DUTY TOOL
PACKAGED IN:	50/BAG, 1,000/CASE

NOTE: THESE CABLE TIES ARE PLENUM RATED AND HAVE A FLAMMABILITY RATING OF V-2.



FASTENER DIVISION
 FITCHBURG, MA 01420 U.S.A.
 TEL. 1-800-225-5913
 FAX. 1-800-848-2169

DESCRIPTION:

21" / 533mm CABLE TIE, HEAVY DUTY
 BLACK HEAT STABILIZED

APPROVAL:

J. Boyle 9-15-2015

STOCK NO.

10607-0

REV

H

AVERY DENNISON MARKETING SPECIFICATION

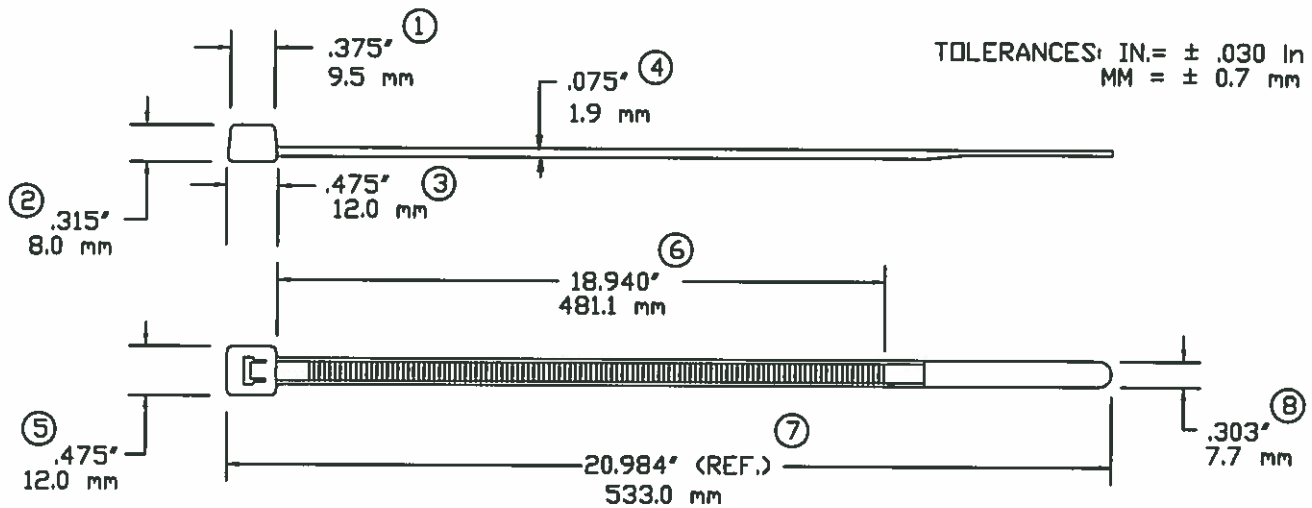

NOT TO SCALE

LOOP TENSILE STRENGTH:	120 LBF / 534N MINIMUM PER AS-23190
OPERATING TEMPERATURE:	-40°F(-40°C) TO 176°F(80°C)
MIN. INSTALLATION TEMP:	32°F(0°C)
MATERIAL:	NYLON 6/6
WEIGHT:	.2924 OZ./8.3 GRAMS
MILITARY STANDARD:	MS-3367-3-0
BUNDLE DIAMETER:	Ø.250"/4.76mm TO Ø6.0"/152.4mm
TOOL TENSION SETTING:	6-8 ON HEAVY DUTY TOOL
PACKAGED IN:	50/BAG, 1,000/CASE

NOTE: THESE CABLE TIES ARE UV RESISTANT AND HAVE A FLAMMABILITY RATING OF V-2.



FASTENER DIVISION
FITCHBURG, MA 01420 U.S.A.
TEL. 1-800-225-5913
FAX. 1-800-848-2169



DESCRIPTION: 21" / 533mm CABLE TIE, HEAVY DUTY BLACK WEATHER RESISTANT	APPROVAL: 	
	STOCK NO. 10608-0	REV H